

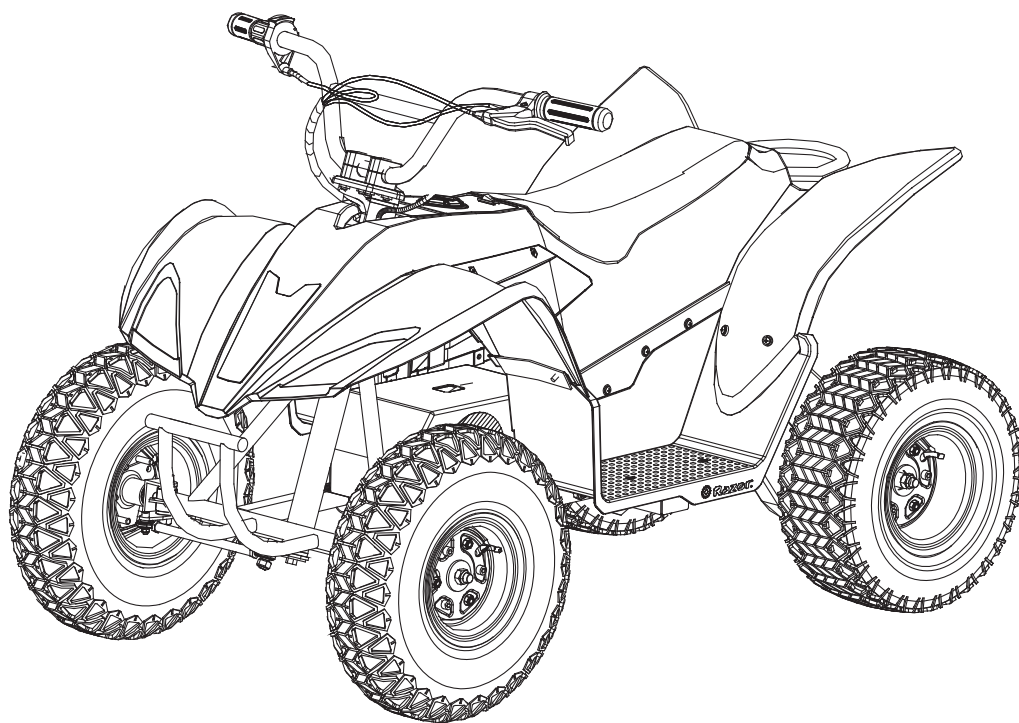

DIRT QUAD 500



OWNER'S MANUAL

**Read and understand this entire manual before allowing child to use this product! For assistance contact Razor.
DO NOT RETURN TO STORE.**

**NOTE: Manual illustrations are for demonstration purposes only.
Illustrations may not reflect exact appearance of actual product.
Specifications subject to change without notice.**

**Please have your product along with the 19 character product I.D. code with you
before contacting Razor for warranty assistance and/or replacement parts.**

Product I.D. Code: _____ - _____ - _____

CONTENTS

Safety Warnings	1-2	Repair and Maintenance.....	6-9
Before You Begin.....	3	Troubleshooting Guide	10
Assembly and Set-Up.....	4	Dirt Quad 500 Parts List.....	11
Charging the Battery/Pre-ride Checklist	5	Warranty Information and Contact Information	14
Usage	6		

SAFETY WARNINGS

⚠ WARNING: This is the “older rider” version of the popular Dirt Quad. It is bigger and faster than the original and it is not intended for riders under 14. Younger riders should not use the Dirt Quad 500, they should ride the original Dirt Quad for ages 8 and up.

⚠ WARNING: Riding a four-wheeled electric product like the Dirt Quad 500 does present potential risks and caution is required. Like any riding product, the Dirt Quad 500 has inherent hazards associated with its use (for example, falling off or riding it into a hazardous situation). Like any riding product, the Dirt Quad 500 can and is intended to move, and it is therefore possible to lose control or otherwise get into dangerous situations. Both children and adults responsible for supervising them must recognize that if such things occur, a rider can be seriously injured or die, even when using safety equipment and other precautions. **RIDE AT YOUR OWN RISK AND USE COMMON SENSE.**

⚠ WARNING: NOT FOR CHILDREN UNDER AGE 14 OR HEAVIER THAN 220 LB (100 KG). Because products, like the Dirt Quad 500, can and do present potential hazards plainly associated with their use, it is well recognized THE NEED FOR EXERCISE OF PARENTAL RESPONSIBILITY IN SELECTING RIDING PRODUCTS APPROPRIATE TO THE AGE OF A CHILD, OR PARENTAL SUPERVISION IN SITUATIONS IN WHICH CHILDREN OF VARIOUS AGES MAY HAVE ACCESS TO THE SAME RIDING PRODUCTS, IS IMPORTANT. Not every product is appropriate for every age or size of child, and different age recommendations are found within this category of product which are intended to reflect the nature of the hazards and the expected mental or physical ability, or both, of a rider to cope with the hazards.

Razor recommends that children under the age of 14 not be permitted to use this product. This recommendation is based not just on age or weight or height – it reflects consideration of expected maturity and skills as well as physical size. The recommended rider age of 14 years or older is only an estimate and can be affected by the rider’s size, weight, or skills – not every rider 14 years old will be suited to the product. Certainly, any rider unable to fit comfortably on the Dirt Quad 500 should not attempt to ride it, but a **parent’s decision to allow his or her child to ride this product should be based on the child’s maturity, skill, and ability to follow rules. Razor emphasizes that adults are strongly advised not to disregard Razor’s recommendations or permit younger children to ride the Dirt Quad 500.**

Persons with any mental or physical conditions that may make them susceptible to injury, impair their physical dexterity or mental capabilities to recognize, understand, and follow safety instructions and to be able to understand the hazards, should not use or be permitted to use products inappropriate for their abilities. Persons with heart conditions, head, back or neck ailments (or prior surgeries to these areas of the body), or pregnant women, should be cautioned not to operate such products.

NOTICE: This manual contains many warnings and cautions concerning the consequences of failing to maintain, inspect or properly use your electric ride-on product. Because any incident can result in serious injury or even death, we do not repeat the warning of possible serious injury or death each time such a possibility is mentioned.

DO NOT EXCEED THE WEIGHT LIMIT OF 220 lb. Rider weight does not necessarily mean a person’s size is appropriate to fit or maintain control of the Dirt Quad 500.

CHECK AND MAINTAIN PRODUCT CONDITIONS

Before use, check to confirm that any and all chain guards or other covers and guards are in place and in serviceable condition. Check that the brake is functioning properly, and that tires are inflated properly and have sufficient tread remaining. The product should be maintained and repaired in accordance with the manufacturer’s specifications, using

only the manufacturer’s authorized replacement parts, and should not be modified from the manufacturer’s original design and configuration. Replace worn or broken parts immediately.

ACCEPTABLE RIDING PRACTICES AND CONDITIONS

Always check and obey any local laws or regulations which may affect the locations where the Dirt Quad 500 may be used.

Ride defensively. Watch out for potential obstacles that could catch your wheel(s) or force you to swerve suddenly or lose control. Be careful to avoid pedestrians, skaters, skateboards, scooters, bikes, children or animals who may enter your path, and respect the rights and property of others.

The Dirt Quad 500 is meant to be used on private property and on closed courses and not on public streets or sidewalks. Do not ride your electric four wheeler in any areas where pedestrian or vehicle traffic are present.

Do not activate the speed control on the hand grip unless you are on the electric four wheeler and in a safe, outdoor environment suitable for riding.

This product was manufactured for performance and durability, but is not impervious to damage. Jumping or other aggressive riding can overstress and damage any product, including the Dirt Quad 500, and the rider assumes all risks associated with high-stress activity.

Be careful and know your limitations. Risk of injury increases as the degree of riding difficulty increases. The rider assumes all risk associated with aggressive riding activities.

Maintain a hold on the handlebars at all times.

Never carry passengers or allow more than one person at a time to ride the electric four wheeler.

Never use near steps or swimming pools.

Do not allow hands, feet, hair, body parts, clothing, or similar articles, to come in contact with moving parts of the Dirt Quad 500, including the brake, wheels and drive train, while the motor is on. Do not touch the brakes or electric motor on your electric four wheeler when in use and/or immediately after riding, as they can become very hot.

Never use headphones or a cell phone to talk or text when riding.

Never hitch a ride with another product.

Do not ride the Dirt Quad 500 in wet or icy weather and never immerse the electric four wheeler in water, as the electrical and drive components could be damaged by water or create other possible unsafe conditions.

Wet, slick, bumpy, uneven or rough surfaces may increase risks of use. Do not ride the electric four wheeler in mud, ice, puddles or water. Avoid excessive speeds that can be associated with downhill rides. Never risk damaging surfaces, such as carpet or flooring, by use of an electric four wheeler indoors.

Do not attempt or do stunts or tricks on your electric four wheeler. These four wheelers are not made to withstand abuse from misuse, such as jumping, curb grinding or any other type of stunts. Racing, stunt riding, or other maneuvers also enhance risk of loss of control, or may cause uncontrolled rider actions or reactions.

Do not ride at night or when visibility is limited.

PROPER RIDING ATTIRE

Always wear proper protective equipment, such as an approved safety helmet (with chin strap securely buckled), elbow pads and kneepads. A helmet may be

SAFETY WARNINGS

legally required by local law or regulation in your area. A long-sleeved shirt, long pants and gloves are recommended. Always wear athletic shoes (lace-up shoes with rubber soles), and keep shoelaces tied and out of the way of the wheels, brake, motor and drive system. Never ride barefooted or in sandals.

USING THE CHARGER

The charger supplied with the electric four wheeler should be regularly examined for damage to the cord, plug, enclosure and other parts, and in the event of such damage, the four wheeler must not be charged until the charger has been repaired or replaced.

Use only with the recommended charger.

Use caution when charging.

The charger is not a toy. Charger should be operated by an adult.

Do not operate charger near flammable materials.

Unplug charger and disconnect from Dirt Quad 500 when not in use.

Always disconnect from the charger prior to wiping down and cleaning your Dirt Quad 500 with a damp cloth.

FAILURE TO USE COMMON SENSE AND HEED THE ABOVE WARNINGS FURTHER INCREASES RISK OF SERIOUS INJURY. USE AT YOUR OWN RISK AND WITH APPROPRIATE AND SERIOUS ATTENTION TO SAFE OPERATION. USE CAUTION.

Need Help? Visit our web site for replacement parts, product support, a list of authorized service centers in the US and customer service contact information at www.razor.com. Please have the product I.D. code (located on the white label of your product) available for better assistance. Additional Customer Service contact information is listed at the back of this manual.

BEFORE YOU BEGIN

Remove contents from box. Remove the cardboard separators that protect the components from damage during shipping. Inspect the contents of the box for scratches in the paint, dents or kinked cables that may have occurred during shipping. Because the Dirt Quad 500 is 95 percent assembled and packed at the factory, there should not be any problems, even if the box has a few scars or dents.

MAKE SURE POWER SWITCH IS TURNED "OFF" BEFORE CONDUCTING ANY MAINTENANCE PROCEDURES.

Estimated Assembly and Set-Up Time

Razor recommends assembly by an adult.

Allow up to 10 minutes for assembly, not including initial charge time.

Allow up to 12 hours for initial charge (see page 5 for charging information).

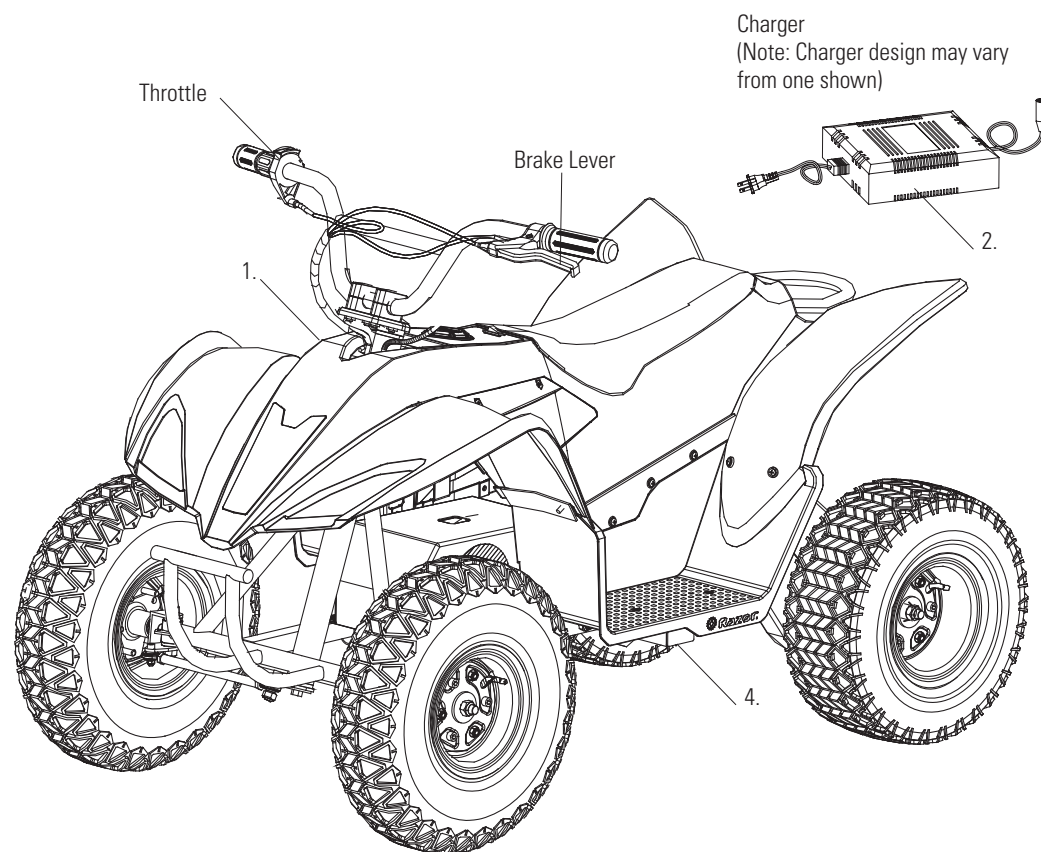

WARNING:
DO NOT USE NON-RAZOR PRODUCTS WITH YOUR RAZOR DIRT QUAD 500. The Dirt Quad 500 has been built to certain Razor design specifications. The original equipment supplied at the time of sale was selected on the basis of its compatibility with the frame and all other parts. Certain aftermarket products may not be compatible and will void your warranty.

Product ID Locations:

1. Footstep (Right Side)
2. Charger
3. Box (Not Shown)
4. Bottom of the Frame (Underneath the Unit)

Required Tools (Included)

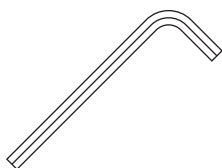

6 mm Allen Wrench

Plastic Bag Contents:

- Charger
- Allen Wrench
- Owner's Manual

ASSEMBLY AND SET-UP

□ Attaching the Handlebars

Tool Required: 6 mm Allen Wrench

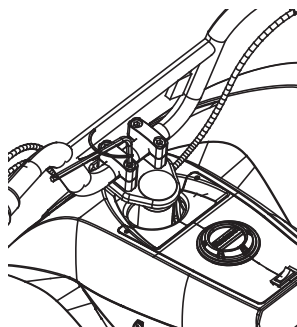

1 Using the 6 mm Allen wrench, remove bolts from handlebar clamp.

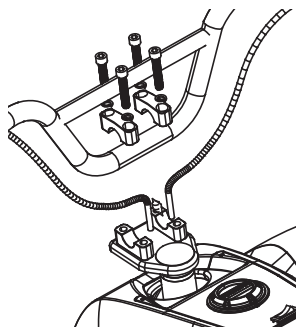

2 Place handlebars in handlebar clamp in upright, vertical position.

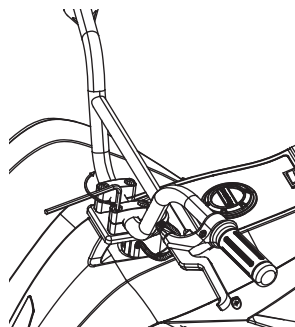

3 Insert bolts and tighten securely. When properly tightened, the handlebars should not move forward or back.

Note: The gap between the upper clamp and lower clamp should be equal on both sides of handlebar.

□ Inflating the Tires

Tires are inflated when shipped, but they invariably lose some pressure between the point of manufacturing and your purchase. Inflate the tires to the correct PSI before first time use.

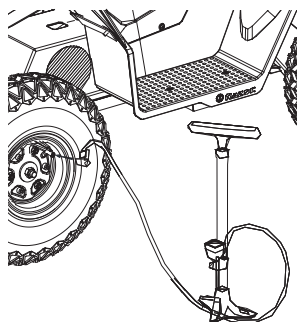

Lower air pressure can result in a shorter ride time. Periodically check all four tires. Reinflate when needed.

Using a bicycle tire pump equipped for a Schrader valve, inflate the tires to the PSI indicated on the sidewall of the tire.

□ Testing the Brake

To use the brake, squeeze the lever to increase the pressure on the brake. The brake lever is fitted with a cable adjuster to compensate for cable stretch and/or to fine-tune the lever movement to brake engagement. If brake is not engaging properly, follow instructions for adjusting the brakes outlined on page 7.

⚠ **WARNING:**

Failing to properly adjust and tighten the bolts that affix the handlebars can cause you to lose control and crash.

⚠ **WARNING:**

Do not use the Dirt Quad 500 for the first time until you have inflated the tires to the correct PSI. Failure to do so may damage your product and void your warranty.

⚠ **WARNING:**

Do not over inflate, as this could damage the tire or wheel.

Note: The pressurized air supplies found at gasoline stations are designed to inflate high-volume automobile tires. If you decide to use such an air supply to inflate your tires, first make sure the pressure gauge is working, then use very short bursts to inflate to the correct PSI. If you inadvertently over-inflate the tire, release the excess pressure immediately.

Need Help? Visit our web site for replacement parts, product support, a list of authorized service centers in the US and customer service contact information at www.razor.com. Please have the product I.D. code (located on the white label of your product) available for better assistance. Additional Customer Service contact information is listed at the back of this manual.

CHARGING THE BATTERY

□ Charging the Battery

Your Dirt Quad 500 may not have a fully charged battery; therefore you must charge the battery prior to use.

- Initial charge time: 12 hours.
- Recharge time: up to 12 hours, even if the light turns green. Recommended maximum charging time is 24 hours.
- Always charge the battery immediately after riding.
- Fully charge battery before storing for extended periods of time.
- Unplug charger from the wall outlet when not in use.
- Failure to recharge battery periodically may result in a battery that will not accept a charge.
- Make sure the Dirt Quad 500 power switch is turned **OFF** when unit is not in use. If the power switch is left on for an extended period of time, the battery may reach a stage at which it will no longer hold a charge.
- To ensure long battery life, never store the product in freezing or below freezing temperatures! Freezing will permanently damage the battery.
- Run time: Up to 60 minutes of continuous ride time. Run time may vary depending on riding conditions, rider weight, climate, and/or proper maintenance.
- Constant stopping and starting may shorten ride time.
- Battery life can vary depending on proper maintenance and usage of the unit.

Charger

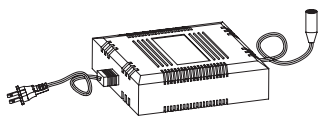

Make sure the power switch is in the OFF position.

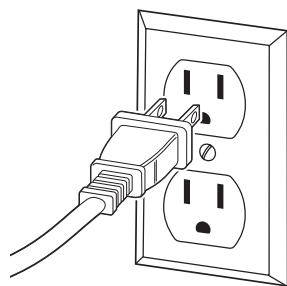

- 1** Plug the charger plug into wall outlet. The light on the charger should be green.
Note: If green light (LED) does not turn on, try a different outlet.

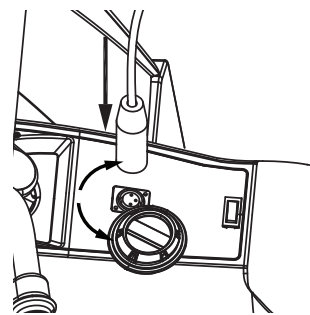

- 2** Slide, do not pull, charger port cover to one side and plug charger into charger port. The light on the charger should turn red during charging. The light will turn green again when charging is complete.
Note: Slide cover back over the charger port when charging is complete.

! WARNING:

Use **ONLY** with the recommended charger. Batteries are only to be charged under adult supervision. The charger is not a toy. Always disconnect the charger before wiping down and/or cleaning the Dirt Quad 500 with a damp cloth.

The charger supplied with the Dirt Quad 500 should be regularly examined for damage to the cord, plug, enclosure and other parts. In the event of such damage, the Dirt Quad 500 must not be charged until it has been repaired or replaced.

Chargers have built-in over-charge protection to prevent battery from being over-charged.

Note: If the charger gets warm during regular use, this is a normal response and is no cause for concern. If your charger does not get warm during use, it does not mean that it is not working properly.

Wall outlet - Green (stand by)
Wall outlet and Unit - Red (Charging)
Charging complete - Green (Charged)

Note: Continue charging unit even if light turns green prior to 12 hours.

! WARNING:

Battery charge can deplete over time. Periodically recharge battery when not in use.

PRE-RIDE CHECKLIST



Brake

Check the brake for proper function. When you squeeze the lever, the brake should provide positive braking action. When you apply the brake with the speed control on, the brake cut-off switch will stop the motor.



Tires

Periodically inspect the tires for excess wear and replace as needed. Regularly check the tire pressure and inflate as needed. If you get a flat tire, the inner tube can be patched or a new tube can be purchased from Razor or an authorized repair center.



Frame and Handlebars

Check for cracks or broken connections. Although broken frames are rare, it is possible for an aggressive rider to run into a curb or object and wreck, bend or break the frame. Get in the habit of inspecting your product on a regular basis.



Hardware/Loose Parts

Check and secure all fasteners before every ride. There should not be any unusual rattles or sounds from loose parts or broken components. If the unit is damaged, do not ride. **Reference "Safety Warnings" on pages 1 and 2 of this manual.**



Safety Gear

Always wear proper protective gear, such as an approved safety helmet. Elbow pads, kneepads, pants and long sleeves are recommended. Always wear closed toe shoes (lace-up with rubber soles) and keep shoelaces tied and out of the way of the wheels, motor and drive system. **NEVER RIDE BAREFOOTED OR IN SANDALS.**



Laws and Regulations

Always check and obey any local laws or regulations.



Insurance

Do not assume that your existing insurance policies necessarily provide coverage for electric product use. Check with your insurance company for information regarding insurance.

USAGE

Starting the Dirt Quad 500

To start unit, while seated on seat, turn on power switch; place both hands on handlebars and apply the throttle with right hand.

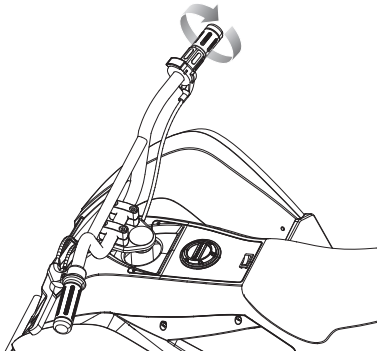

Stopping the Dirt Quad 500

To stop unit, release the throttle and apply the brake until the four wheeler comes to a complete stop.

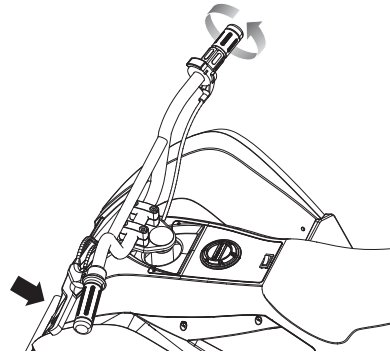

REPAIR AND MAINTENANCE

Turn power switch OFF before conducting any maintenance procedures.

- Read the instructions
- Remove charger plug
- Turn the power switch OFF
- Secure the unit under repair
- Exercise caution around exposed parts
- Contact Razor customer service if unsure about any repair or maintenance

Replacing Battery

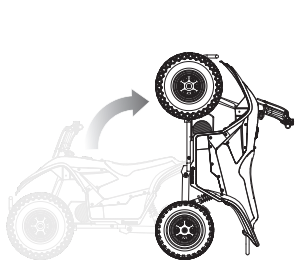

1 Carefully stand unit upright as shown above.

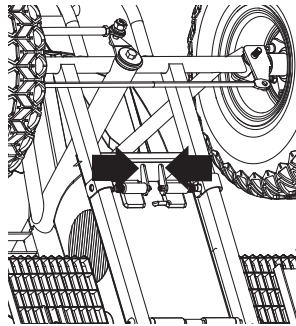

2 Locate battery compartment and squeeze metal tabs to gain access to the batteries.

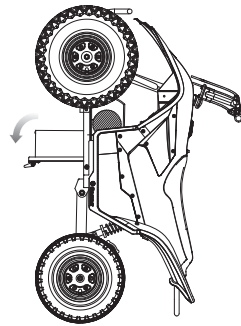

3 Carefully lower battery tray.

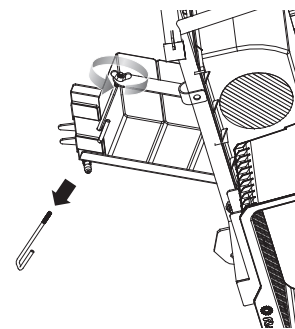

4 Loosen wing nut located on the top of the battery strap and remove pin.

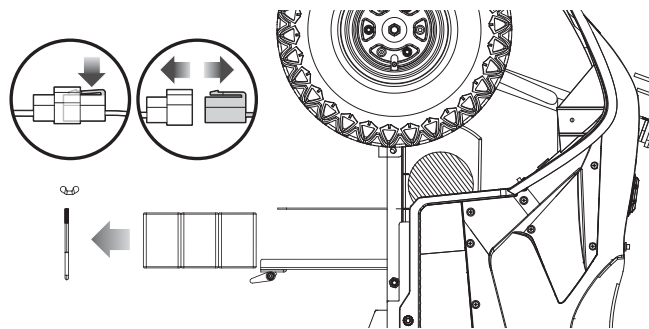

5 Depress the plastic tab on the battery connector to disconnect the batteries. Using both hands, carefully remove batteries from unit.

Need Help? Visit our web site for replacement parts, product support, a list of authorized service centers in the US and customer service contact information at www.razor.com. Please have the product I.D. code (located on the white label of your product) available for better assistance. Additional Customer Service contact information is listed at the back of this manual.

REPAIR AND MAINTENANCE

□ Adjusting the Brake

Tool Required: 5 mm Allen wrench

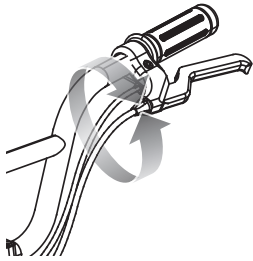

1 To adjust the tension, thread the brake lever adjuster in or out 1/4 to 1/2 turn until the desired brake adjustment is attained. Most adjustments are complete at this step. If brake still needs further adjustment, proceed to step 2 for disc brake.

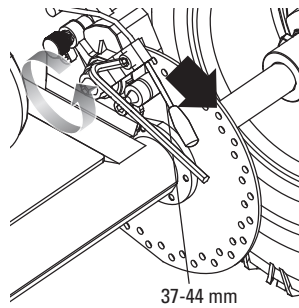

2 Locate the brake caliper and disc brake behind the right rear wheel. The distance of the brake cable between the end of the cable and the anchor bolt should be between 37 and 44 mm. If the disc brake has too much play, loosen the rear anchor bolt with a 5 mm Allen wrench and pull the brake cable tighter (direction indicated with arrow).

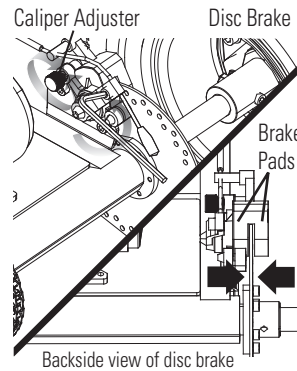

3 If the brake pads are rubbing against the disc brake, use your fingers to twist the caliper adjuster in either direction until disc is centered evenly between the pads.

⚠ WARNING:

The brake is capable of causing the electric four wheeler to skid the tire throwing an unsuspecting rider. Practice in an open area free from obstacles until you are familiar with the brake function. Avoid skidding to a stop as this can cause you to lose control or damage the rear tire(s).

□ Replacing the Fuse

Make sure the power switch is turned **OFF**.

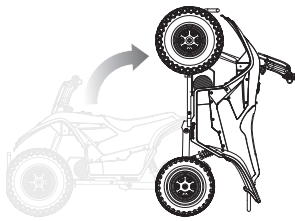

1 Carefully stand unit upright as shown above.

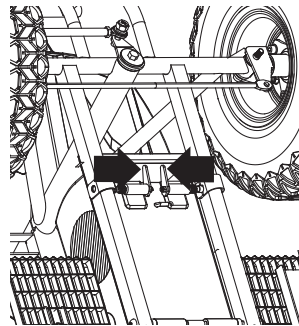

2 Locate battery compartment and squeeze metal tabs to gain access to the batteries.

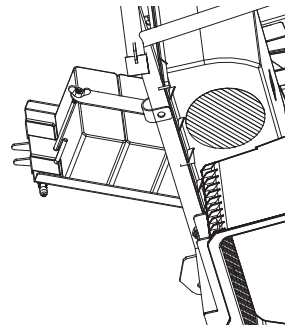

3 Carefully lower battery tray. Locate the fuse box attached to the top of the batteries.

⚠ WARNING:

To prevent shock, please follow the instructions accordingly and do not skip or combine any steps.

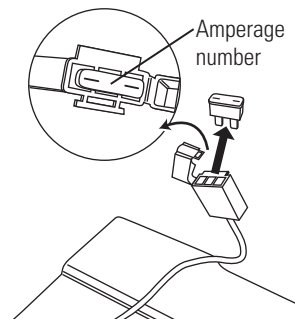

4 Open the fuse box and remove fuse. Replace with a new one of equal amperage. **Note:** Amperage rating is located on top of fuse.

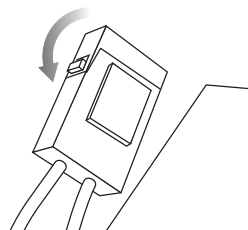

5 Close the fuse cover.

REPAIR AND MAINTENANCE

□ Replacing the Chain

Tools Required: 5 mm Allen Wrench, 19 mm Wrench, 10 mm Wrench and Phillips Screwdriver.

⚠ WARNING:
Do not touch motor after use.
Motor is (or can be) very hot.

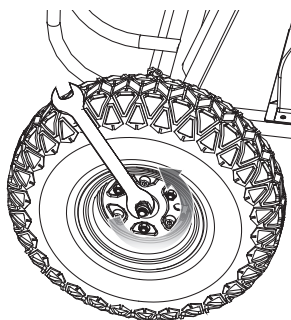

1 Using a 19 mm wrench, remove center bolt and washers.

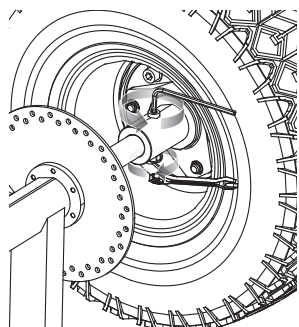

2 Using a 5 mm Allen wrench and 10 mm wrench, remove the nut and bolt from the rear axle on the inside of the rear wheel as shown. Remove wheel.

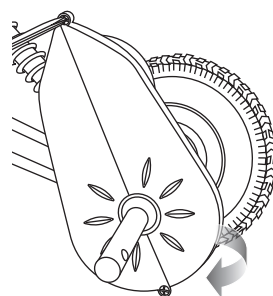

3 Remove the three (3) Phillips screws from the upper half of the chain guard and remove.

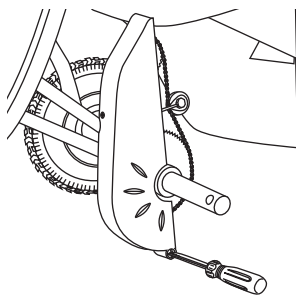

4 Remove the two (2) Phillips screws from the lower half of the chain guard and remove.

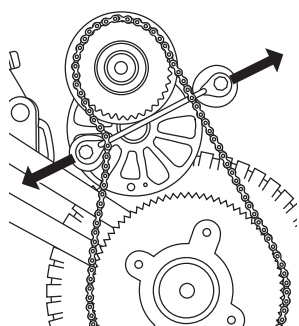

5 Spread the chain tensioner apart to loosen chain.

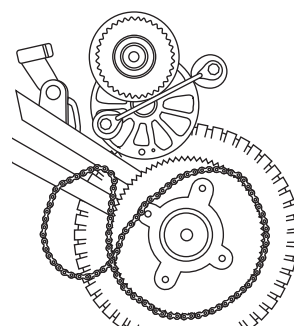

6 Remove the chain around the rear and motor sprockets. Install replacement chain

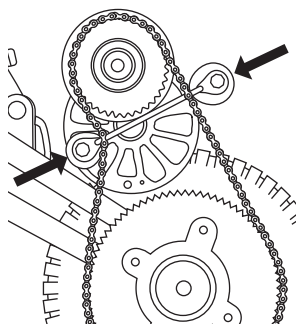

7 Reset chain tensioner.

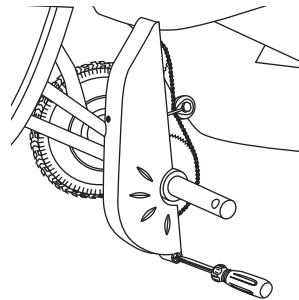

8 Position lower half of the chain guard to align mounting holes and re-attach securely to frame.

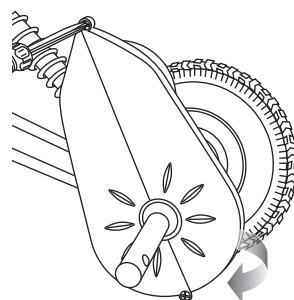

9 Position upper half of the chain guard to align mounting holes and re-attach securely to frame.

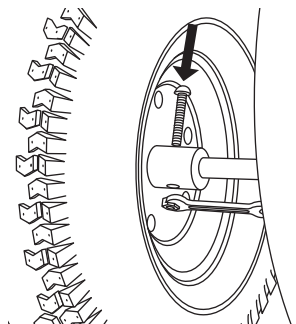

10 Re-insert the bolt through the rear axle on the inside of the rear wheel and securely tighten with nut.

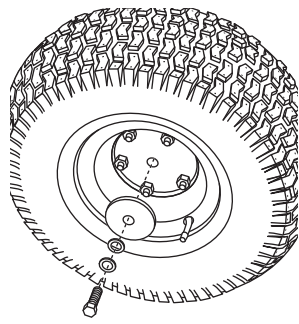

11 Re-insert the hardware removed in step 1 and securely tighten in place.

REPAIR AND MAINTENANCE

❑ Replacing the Wheels

Tools Required: 19 mm Wrench, 10 mm Wrench, 6 mm Allen Wrench, 5 mm Allen Wrench

Front Wheel

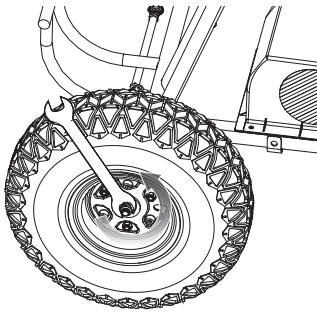

1 Using a 19 mm wrench, remove center axle nut. Remove wheel.

Rear Wheel

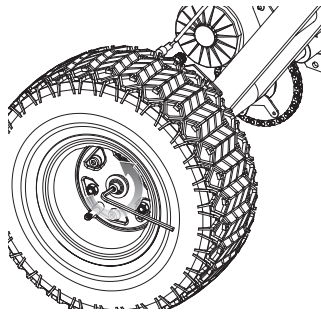

1 Using a 6 mm Allen wrench, remove center bolt and washers.

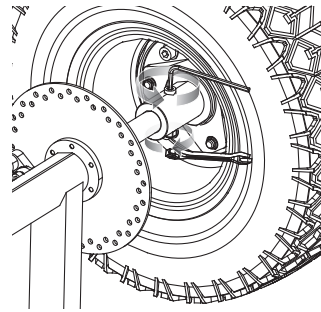

2 Using a 5 mm Allen wrench and 10 mm wrench, remove the nut and bolt from the rear axle on the inside of the rear wheel as shown. Remove wheel.

❑ Chain and Sprocket

The chain will typically have a “loose spot” and “tight spot” corresponding with a particular sprocket rotational position. This is normal and common to all chain-driven products due to run-out tolerances of the freewheel and sprocket. Proper chain alignment must be maintained. If the chain is noisy or rough running, check the lubrication, tension and alignment of the sprockets, in that order. The chain tensioner must be aligned and free from binding and the tensioner spring(s) must be operating correctly.

❑ Battery Care and Disposal

Do not store in freezing or below freezing temperatures. To properly maintain your battery and ensure maximum battery life, carefully read the “Charging the Battery” section on page 5 of this owner’s manual.



CONTAINS SEALED LEAD ACID BATTERIES. BATTERIES MUST BE RECYCLED.

Disposal: Your Razor product uses sealed lead-acid batteries which must be recycled or disposed of in an environmentally safe manner. Do not dispose of a lead-acid battery in a fire. The battery may explode or leak. Do not dispose of a lead-acid battery in your regular household trash. The incineration, land filling or mixing of sealed lead-acid batteries with household trash is prohibited by law in most areas. Return exhausted batteries to a federal or state approved lead-acid battery recycler or a local seller of automotive batteries. If you live in Florida or Minnesota, it is prohibited by law to throw away lead-acid batteries in the municipal waste stream.

❑ Charger

The charger supplied with the Dirt Quad 500 should be regularly examined for damage to the cord, plug, enclosure and other parts, and in the event of such damage, the product must not be charged until it has been repaired or replaced.

Use **ONLY** with the recommended charger.

❑ Wheels

Wheels and drive system are subject to normal wear and tear. It is the responsibility of the user to periodically inspect wheels for excess wear and adjust and replace drive train components as required.

❑ Replacement Parts

The most frequently requested replacement parts are available for purchase at some Razor retail partners. For the complete selection of replacement parts visit shop.razor.com.

❑ Repair Centers

For a list of authorized Razor repair centers:

- Check online at www.razor.com.
- Additional Customer Service contact information is listed on the back of this manual.

⚠ WARNING:

To avoid a pinch or injury, keep fingers away from moving sprockets and chain.

⚠ WARNING:

If a battery leak develops, avoid contact with the leaking acid and place the damaged battery in a plastic bag. Refer to the disposal instructions at left. If acid comes into contact with skin or eyes, flush with cool water for at least 15 minutes and contact a physician.

Need Help? Visit our web site for replacement parts, product support, a list of authorized service centers in the US and customer service contact information at www.razor.com. Please have the product I.D. code (located on the white label of your product) available for better assistance. Additional Customer Service contact information is listed at the back of this manual.

TROUBLESHOOTING GUIDE

*Unit(s) should be turned off and fully charged prior to doing any Troubleshooting

NOTE: All troubleshooting steps should be performed by an adult only

Problem	Possible Cause	Solution
Product does not run.	Product is rolling backwards	Throttle will not engage if the product is rolling backwards. Come to a complete stop and then activate the throttle.
	Undercharged battery	Charge the battery. A new battery should have been charged for at least 12 hours before using the product for the first time and up to 12 hours after each subsequent use. Check all connectors. Make sure the charger connector is tightly plugged into the charging port, and that the charger is plugged into the wall.
Product suddenly stopped working while in use	Loose wires or connectors	Check all wires and connectors to make sure they are tight.
	Burned-out fuse	The fuse will burn out and automatically shut off the power if the motor is overloaded. An excessive overload, such as too heavy a rider or too steep a hill, could cause the motor to overheat. Refer to replacing the fuse instructions on page 7 of this manual. Correct the conditions that caused the fuse to burn out and avoid repeatedly burning out fuse.
	Motor or electrical switch damage	Contact your local Razor authorized service center for diagnosis and repair.
Short run time (less than 15 minutes per charge)	Undercharged battery	Charge the battery. A new battery should have been charged for at least 12 hours before using the product for the first time and up to 12 hours after each subsequent use. Check all wires and connectors. Make sure the battery connector is tightly plugged into the charger connector, and that the charger is plugged into the wall.
	Brakes are not adjusted properly	Refer to brake adjustment instructions on page 7 of this manual.
Product runs sluggishly	Riding conditions are too stressful	Use only on solid, flat clean and dry surfaces such as pavement or level ground.
	Tires are not properly inflated	The tires are inflated when shipped, but they invariably will lose some pressure between the point of manufacturing and your purchase. Refer to instructions on page 4 of this manual to properly inflate tires.
	Product is overloaded	Make sure you do not overload the product by allowing more than one rider at one time, exceeding the maximum weight limit, going up too steep a hill or towing objects behind the product.
Sometimes the product doesn't run, but other times it does	Loose wires or connectors	Check all wires around the motors and all connectors to make sure they are tight.
	Motor or electrical switch damage	Contact your local Razor authorized service center for diagnosis and repair.
Product makes loud noises or grinding sounds	Chain is too dry	Apply a lubricant such as 3 in 1™ or Tri-Flow™ to the chain.

For more troubleshooting tips, a list of available replacement parts or to locate an authorized Service Center in your area, visit our website at www.razor.com or call toll free +1 866 467 2967 to speak to a live Customer Service Representative

Need Help? Visit our web site for replacement parts, product support, a list of authorized service centers in the US and customer service contact information at www.razor.com. Please have the product I.D. code (located on the white label of your product) available for better assistance. Additional Customer Service contact information is listed at the back of this manual.

DIRT QUAD 500 PARTS

Keep your Dirt Quad 500 running for years with genuine Razor parts. Visit our web site or e-mail us for more information on spare part availability. (Specifications subject to change without notice.)

- | | |
|---------------------------------|-------------------------------|
| 1. Handlebar Grips (Right/Left) | 12. Motor (500W) |
| 2. Throttle | 13. Chain Tensioner |
| 3. Handlebar | 14. Rear Wheel Complete (x2) |
| 4. Brake Lever Assembly | 15. Chain Guard (Upper/Lower) |
| 5. Handlebar Clamps (x2) | 16. Sprocket |
| 6. Front Wheel Complete (x2) | 17. Chain |
| 7. Adjustable Tie Rod | 18. Disc Brake |
| 8. Spindle Arms (Right/Left) | 19. Caliper Brake |
| 9. Battery (3-12V/7Ah) w/ Fuse | 20. Plastic Body With Seat |
| 10. Battery Tray | 21. Control Module |
| 10-1 Battery Strap | 22. On/Off Switch |
| 11. Battery Cover | 23. Charger Port |

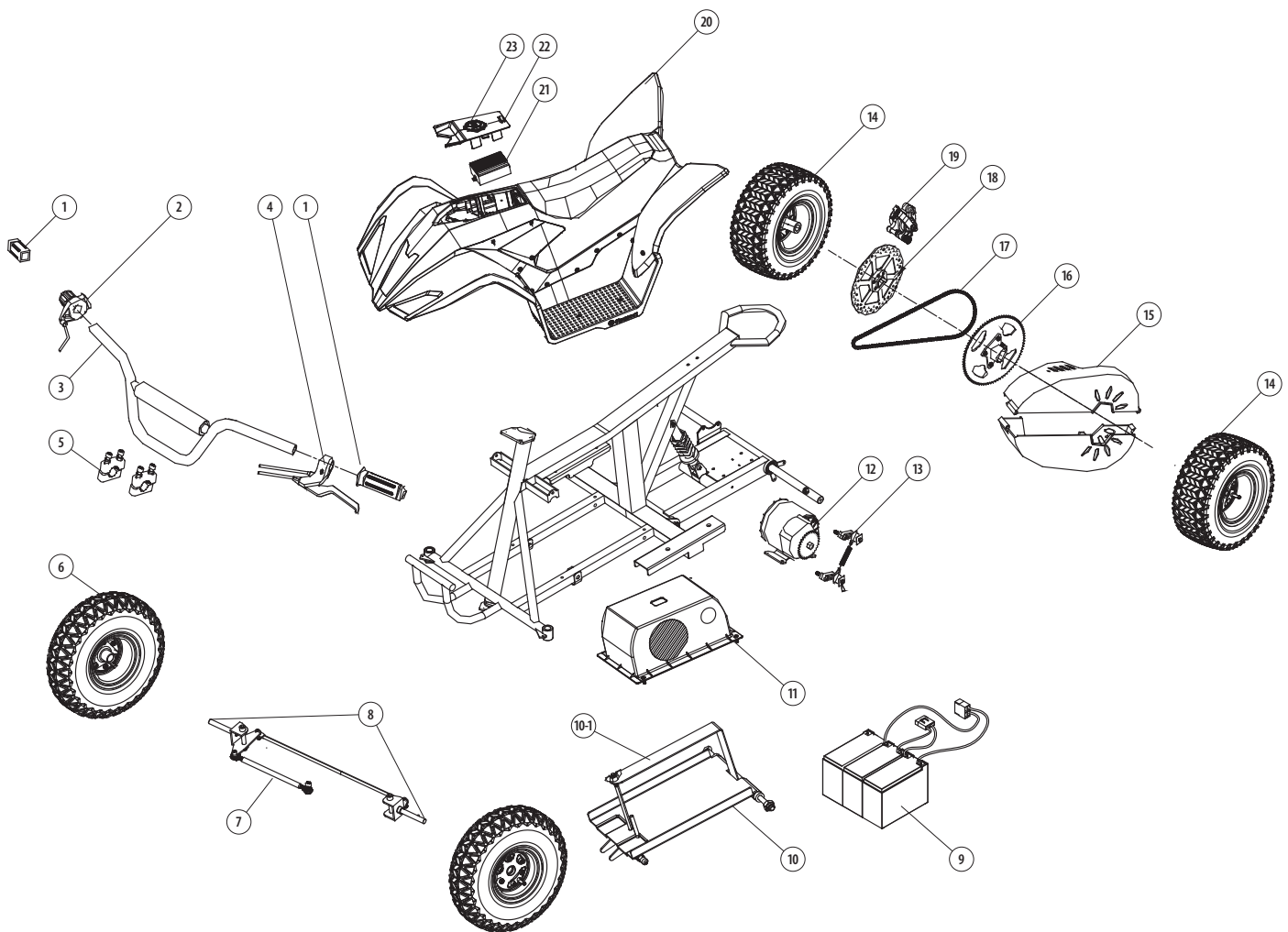

NOTICE: INSURANCE

YOUR INSURANCE POLICIES MAY NOT PROVIDE COVERAGE FOR ACCIDENTS INVOLVING THE USE OF THIS ELECTRIC RIDE-ON PRODUCT. TO DETERMINE IF COVERAGE IS PROVIDED, YOU SHOULD CONTACT YOUR INSURANCE COMPANY OR AGENT.

FCC COMPLIANCE

This device complies with Part 15 of the FCC Rules. Operation is subject to the following two conditions: (1) This device may not cause harmful interference, and (2) this device must accept any interference received, including interference that may cause undesired operation.

Note: This equipment has been tested and found to comply with the limits for a Class B digital device, pursuant to part 15 of the FCC Rules. These limits are designed to provide reasonable protection against harmful interference in a residential installation. This equipment generates, uses and can radiate radio frequency energy and, if not installed and used in accordance with the instructions, may cause harmful interference to radio communications. However, there is no guarantee that interference will not occur in a particular installation. If this equipment does cause harmful interference to radio or television reception, which can be determined by turning the equipment off and on, the user is encouraged to try to correct the interference by one or more of the following measures:

- Reorient or relocate the receiving antenna.
- Increase the separation between the equipment and receiver.
- Connect the equipment into an outlet on a circuit different from that to which the receiver is connected.
- Consult the dealer or an experienced radio/TV technician for help.

⚠ WARNING: Changes or modifications to this unit not expressly approved by Razor USA, could void the user's authority to operate the equipment.

WARRANTY

Razor Limited Warranty

The manufacturer warrants this product to be free of manufacturing defects for a period of 90 days from date of purchase. This Limited Warranty does not cover normal wear and tear, tires, tubes or cables, or any damage, failure or loss caused by improper assembly, maintenance, storage or use of the Razor Dirt Quad 500.

This Limited Warranty will be void if the product is ever:

- used in a manner other than for recreation or transportation;
- modified in any way;
- rented.

The manufacturer is not liable for incidental or consequential loss or damage due directly or indirectly to the use of this product.

Razor does not offer an extended warranty. If you have purchased an extended warranty, it must be honored by the store at which it was purchased.

For your records, save your original sales receipt with this manual and write the serial number below.

CUSTOMER SERVICE CONTACT INFORMATION

Need Help? Visit our web site for replacement parts, product support, a list of authorized service centers in the US and customer service contact information at www.razor.com. Please have the product I.D. code (located on the white label of your product) available for better assistance. Additional Customer Service contact information is listed below:

AMERICAS

Razor USA LLC
P.O. Box 3610
Cerritos, CA 90703
USA

+1 866 467 2967
Monday - Friday
8:00 AM - 5:00 PM Pacific Time

EUROPE

Razor USA LLC (Europe)
Handelsweg 2
2742 RD Waddinxveen
Netherlands

+44 (0) 1202 672702

ASIA

Razor USA LLC (Asia)
P.O. Box 3610
Cerritos, CA 90703
USA

+81 50 7579 6622
info@razor-asia.com

DISTRIBUTED IN THE UK BY:

Re:creation Limited
2 Meadows Business Park
Station Approach, Blackwater
Camberley, Surrey GU17 9AB
United Kingdom

+44 (0) 118 973 6222 *Tel*
+44 (0) 118 973 6220 *Fax*
sales@recreationltd.co.uk

DISTRIBUTED IN AUSTRALIA BY:

Funtastic Limited
Level 2, Tower 2, Chadstone Place
1341 Dandenong Road
Chadstone VIC 3148
Australia

+1 800 244 543
info@funtastic.com.au

Printed in China for:
Razor USA LLC
PO Box 3610
Cerritos, CA 90703

Copyright © 2003 - 2016 Razor USA LLC. All rights reserved. RAZOR and the Razor logo design are among the registered trademarks of Razor USA LLC in the United States and/or select foreign countries.